

ST40

FAST SALAMANDERS HI-TOUCH

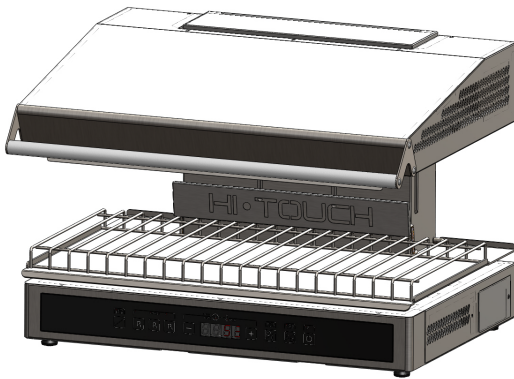

- Exclusive patented heating system.
- Cooktop in stainless steel grill.
- Wall support standard on all units.
- Dish detection function.
- HOLD function.
- Touch screen.
- Possibility of storing three different cooking programmes which can be selected by means of the keys P1, P2 or P3.

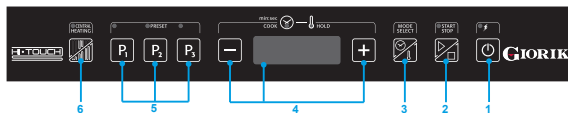

- 1 On/off switch.
- 2 Start/stop button for cooking/maintenance cycles.
- 3 Selection button for cooking mode (timed) or maintenance mode (unlimited duration).
- 4 Timer setting (max 20' in cook mode) and selection of maintenance among 8 levels in a temperature range from 40 to 70°C.
- 5 Setting and selecting Cooking program.
- 6 On/Off button for the heating elements.

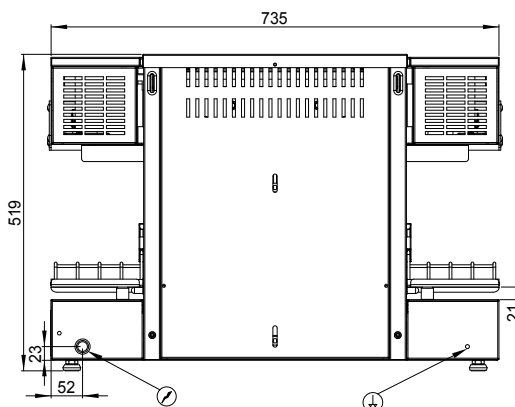
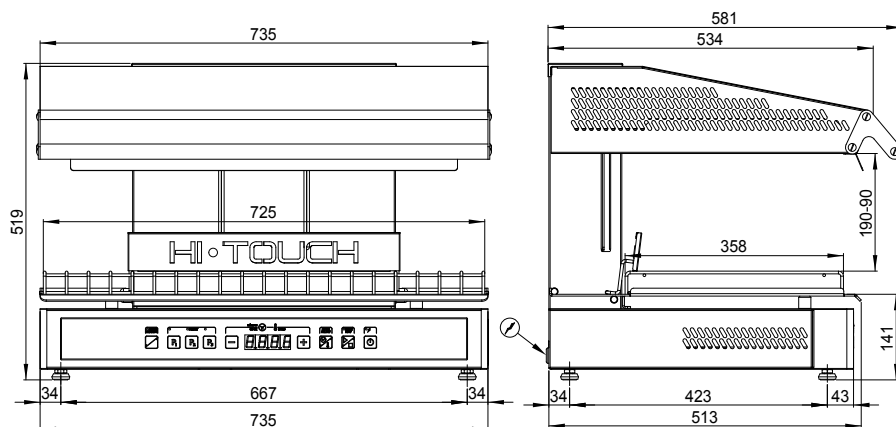

GENERAL TECHNICAL DATA

Package dimension (wxdxh)	cm 83x65x73
Package volume	m ³ 0,4
Weight	kg 80,5
Oven chamber power	-
Absorbed power	kW 6
Power supply voltage	3N 400V 50/60Hz
Power supply voltage (available)	1N 230V 50/60Hz